

## BYPASS ISOLATION TRANSFER SWITCHES

### THOMSON TECHNOLOGY TS 870 BYPASS ISOLATION TRANSFER SWITCHES OFFER THE FOLLOWING OUTSTANDING FEATURES:

#### Enclosed Contact Power Switching Units

- **fully enclosed** silver alloy contacts provide **high withstand** rating & **100% continuous** current rating.
- barriers between the transfer switch and bypass isolation switch reduce the chance of consequential damage if there is a failure in either the transfer switch or bypass isolation switch.
- when isolated there is no power in the transfer switch compartment **providing true isolation**.
- **not damaged if manually switched** while in service since contacts have inherent spring over center design.

#### Reliable Motor-Operated Transfer Mechanism

- **heavy duty** brushless gearmotor and operating mechanism provide mechanical interlocking and extreme long life with minimal maintenance.
- **safe manual operation** with a **permanently affixed handle**, permits easy operation even under adverse conditions.
- all control wires and power busses are **front-accessible**, eliminating the cost and complexity of a drawout transfer switch.

#### Control Features

- **TSC 80** microprocessor based controller.
- **isolation plug** permits disconnecting control circuits from all power sources for safety and convenience.
- control circuitry permits complete **off load testing** of the transfer switch when isolated (a drawout transfer switch is not required.)

#### Isolation Switch

- allows bypass without load interruption (double sided bypass only).

#### Quality Assurance

- ISO 9001:2000 Registered

#### Product Data

- Models from 100-1200 Amp continuous
- Available 3 or 4 pole
- All models 50/60Hz rated
- Voltage range 208-600V
- 3 phase, 3 or 4 wire systems

#### Safety Standards

- CSA C22.2 No. 178/CSA C22.2 No. 31 (in accordance with **CSA 282-00** - Institutional & Residential Buildings Occupancy Group B and C).



**TS 870 - 400 AMP  
 BYPASS ISOLATION TRANSFER SWITCH**

## GENERAL DESCRIPTION

The **Thomson Technology TS 870** bypass isolation transfer switch includes all the features of the **TS 870** transfer switch described in our **TS 870** Automatic Transfer Switch brochure.

The **TS 870** bypass isolation switch incorporates two basic types for bypass-isolation. **Type "B" (double-sided )** isolates the transfer switch and can bypass either the utility or generator source of the load, as selected by the operator. Single-sided bypass types **"D" (utility bypass)** and **"C" (generator bypass)** can bypass only one source to the load (in accordance with **CSA 282-00** - Institutional & Residential Buildings Occupancy Group B and C). Note: CSA 282-00 requires (as a minimum) a single sided bypass on the generator supply.

The **TS 870** series mechanisms utilize enclosed contact power switching units which provide a **100% continuous rating**. The switches are mounted independently on a common frame.

**Independent switching** units provide a degree of reliability and redundancy not available with ganged contactor type bypass systems.

Each switching unit is equipped with an **internal quick-make, quick-break mechanism** as standard, and is **certified to switch without de-energizing any system loads**.

The **single handle bypass mechanism** is permanently mounted, and will not permit the sources to be interconnected. An operator has **three simple steps** to follow when bypassing, for servicing procedures or in cases when there is a transfer switch failure and manual transferring is required. The unique **single handle bypass design** allows bypassing with or without a load interruption (double-sided bypass only). Bypass and isolation position indication is permanently mounted at each switch position allowing the operator to clearly identify which mode the system is in (illuminated position indication is available as an option).

## ONE-LINE SYSTEM DIAGRAM (Typical)

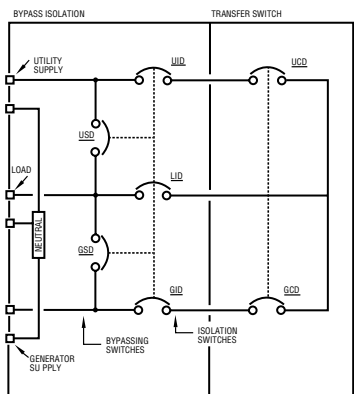

MODEL TS 870 - TYPE "B"

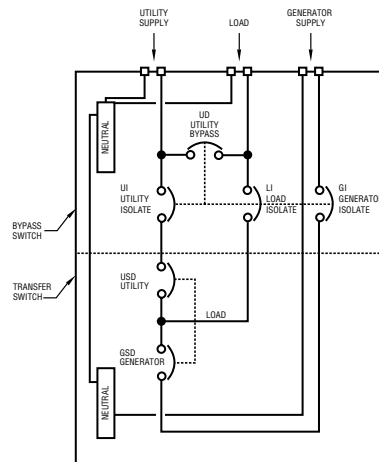

MODEL TS 870 - TYPE "D"

**It is not possible to interconnect the utility and generator sources. No voltage is present at the transfer switch while isolated** (i.e. isolation switches must all be open)

## STANDARD FEATURES

- Load on Utility & Load on Generator Lights
- Utility & Generator Source Available Lights
- Three Phase Voltage Sensing on Utility & Generator Sources
- Under Frequency Sensor on Generator Source
- Engine Start Delay Timer 0-60 sec.
- Engine Cooldown Delay Timer 0-30 min.
- Engine Warm-up Timer 0-60 sec.
- Neutral Position Delay 0-60 sec.
- Utility Return Timer 0-30 min.
- Engine Start Contact (10A, 120/240VAC res. Form C)
- Exercise Timer (On Load, Fixed 20 min.)
- Auxiliary Contact - Utility side (10A, 120/240VAC res. Qty 1, Form C)
- Auxiliary Contact - Generator side (10A, 120/240VAC res. Qty 1, Form C)
- Local Utility Power Fail Simulation Test Pushbutton
- Provision for Remote Load Test/Peak Shave Switch Input
- NEMA 1 Enclosure
- Solid Neutral



## WITHSTAND CURRENT RATINGS (ALL MODELS)

BASIC MODEL	MAXIMUM VOLTAGE	RATED CURRENT (AMPS)	WITHSTAND CURRENT RATING AMPS (RMS)				
			With Upstream Circuit Breaker Protection			With Upstream Fuse Protection	
			@240V	@480V	@600V	@ up to 600V	FUSE TYPE
TS 87xB - 0100	600	100	65,000	25,000	14,000	100,000	T,J
TS 87xB - 0150	600	150	65,000	25,000	14,000	100,000	T,J
TS 87xB - 0200	240	200	65,000	N/A	N/A	N/A	T,J
TS 87xB - 0250	600	250	65,000	35,000	22,000	100,000	T,J
TS 87xB - 0400	600	400	65,000	35,000	22,000	100,000	T,J
TS 87xB - 0600	600	600	65,000	50,000	35,000	100,000	T,J
TS 87xB - 0800	600	800	65,000	50,000	35,000	100,000	Consult Factory
TS 87xB - 1000	600	1000	65,000	50,000	42,000	100,000	Consult Factory
TS 87xB - 1200	600	1200	65,000	50,000	42,000	100,000	Consult Factory

## ENCLOSURE DIMENSIONS/CABLE TERMINALS

(NEMA 1, ASA 61 GRAY)

SINGLE SIDED MODEL	DIMENSIONS (Inches) <sup>1</sup>						SHIPPING WEIGHT		TERMINAL RATING <sup>2</sup>	
	HEIGHT		WIDTH		DEPTH		(lbs)		QTY PER PHASE	RANGE <sup>3</sup>
	3 pole	4 pole	3 pole	4 pole	3 pole	4 pole	3 pole	4 pole		
TS 87xC(D) - 0100 / 0150	51	51	34	34	14	14	205	220	1	#2 - 4/0
TS 87xC(D) - 0200	51	51	34	34	14	14	220	235	1	#6 - 350 MCM
TS 87xC(D) - 0250	51	51	34	34	14	14	220	235	1	#6 - 350 MCM
TS 87xC(D) - 0400	84	84	41	41	15	15	450	500	2	2/0 - 250 MCM
TS 87xC(D) - 0600	84	72	41	66	15	14	510	560	2	2/0 - 500 MCM
TS 87xC(D) - 0800	72	72	66	66	14	14	510	560	3	2/0 - 500 MCM
TS 87xC(D) - 1000/1200	72	72	76	76	17	17	700	740	4	4/0 - 500 MCM

400A : Optional 1 X 500MCM available - Factory installed only.

DOUBLE SIDED MODEL	DIMENSIONS (Inches) <sup>1</sup>						SHIPPING WEIGHT		TERMINAL RATING <sup>2</sup>	
	HEIGHT		WIDTH		DEPTH		(lbs)		QTY PER PHASE	RANGE <sup>3</sup>
	3 pole	4 pole	3 pole	4 pole	3 pole	4 pole	3 pole	4 pole		
TS 87xB - 0100 / 0150	51	51	34	34	14	14	220	240	1	#2 - 4/0
TS 87xB - 0200	51	84	34	41	14	15	230	250	1	#6 - 350 MCM
TS 87xB - 0250	51	84	34	41	14	15	230	490	1	#6 - 350 MCM
TS 87xB - 0400	84	84	41	41	15	15	500	550	2	2/0 - 250 MCM
TS 87xB - 0600	72	72	66	66	14	14	570	650	2	2/0 - 500 MCM
TS 87xB - 0800	72	72	66	66	14	14	570	650	3	2/0 - 500 MCM
TS 87xB - 1000/1200	72	72	76	76	17	17	770	860	4	4/0 - 500 MCM

Optional NEMA 2, 3R & 4X (> 600A only) class enclosures available — consult Thomson Technology.

<sup>1</sup> Enclosure dimensions are for reference. (DO NOT USE FOR CONSTRUCTION).

<sup>2</sup> Optional Terminal Ratings are available in some models - Consult Thomson Technology.

<sup>3</sup> All cable connections suitable for copper or aluminum.

# ORDERING INFORMATION

## ATS MODEL CODE

Specify the following 21 digit ATS MODEL CODE as per the features and applications described below.

1	2	3	4	5	6	7	8	9	10	11	12	13	14	15	16	17	18	19	20	21
T	S		8	7																

### 1-3. SERIES

TS – TRANSFER SWITCH

### 4 & 5. MODEL

87 – 870 SWITCH

### 6. POLES

3 – 3 POLE

4 – 4 POLE

### 7. CONFIGURATION TYPE

B – BYPASS/ISOLATION-DOUBLE SIDED

C – BYPASS/ISOLATION - GENERATOR SIDE ONLY

D – BYPASS/ISOLATION - UTILITY SIDE ONLY\*

### 8-11. AMPERAGE

0100

0150

0200

0250

0400

0600

0800

1000

1200

### 12. APPLICATION

A – STANDARD

X – SPECIAL

### 13. OPERATION TYPE

1 – OPEN TRANSITION

2 – MANUAL ELEC. OP.

X – SPECIAL

### 14. SAFETY STANDARDS

B – CSA C22.2. No. 178/CSA C22.2 No.31

### 15. VOLTAGE

1Ø 3 WIRE

D – 120/240

3Ø 4 WIRE (GROUNDED NEUTRAL)

(\*=MULTI-VOLTAGE CAPABLE)

E – 120/208\*

F – 127/220

G – 120/240\*(DELTA)

H – 220/380\*\*

J – 240/416

K – 254/440

M – 277/480\*

N – 347/600\*

3Ø 3 WIRE

P – 208

Q – 220

R – 240

S – 380\*\*

U – 416

V – 480

W – 600

X – SPECIAL

\*\* FOR 50HZ APPLICATION

### 16. CONTROLLER

1 – TSC 80

7 – NONE (MANUAL)

### 17. ENCLOSURE TYPE

A – NEMA 1, ASA #61 GREY

B – NEMA 2, ASA #61 GREY

C – NEMA 12, ASA #61 GREY

D – NEMA 3R SD, ASA #61 GREY

E – NEMA 3R DD, ASA #61 GREY

F – NEMA 4X, STAINLESS STEEL

G – NONE (OPEN STYLE)

X – SPECIAL

### 18. UTILITY SWITCHING DEVICE

K – MOLDED CASE SWITCH 100-1200A

### 19. GENERATOR SWITCHING DEVICE

K – MOLDED CASE SWITCH 100-1200A

### 20. POWER CONNECTIONS

A – STANDARD

X – SPECIAL

### 21. CONNECTION CONFIGURATION

(SEE DRAWING M-007450-00051)

A – STANDARD

X – SPECIAL

NOTE: \*CSA building code specifies a Generator side Bypass not Utility Side.

## OPTIONAL FEATURES

(Specify separately from ATS MODEL CODE when ordering)

CODE	DESCRIPTIONS	CODE	DESCRIPTIONS
AUX-G	Auxiliary Contact - Generator side (up to qty. 3)	SDM	LCD Service Display Module
AUX-U	Auxiliary Contact - Utility side (up to qty. 3)		- Displays TSC 80 Controller Settings and Timer Adjustments
CEB	Custom Engineered Drawings - Project Specific		- Plug in Connector and Cable
EAP1601	Transfer to Emergency Annunciator, Alarm Horn & Silence Pushbutton	TS-H1	Enclosure Strip Heater c/w Thermostat (120VAC External Power Source Required)
EXT	Programmable Exercise Clock	TS-H2	Enclosure Strip Heater c/w Thermostat (internally powered from ATS load)
FTS-4	4 Function Test Switch (Auto/Off/Engine Start/Test)	TS-O&M	Additional ATS O & M Manuals (Specify qty.) (Alternatively Download from Web)
GPA	Generator Power Available Contact	TS-STG	Shunt Trip Generator Switch
LCK	Enclosure Lockable Door	TS-STU	Shunt Trip Utility Switch
LDC	Generator Pre/Post & Utility Pre/Post Timer Contacts (adjustable) for Load Disconnect prior to Transfer	UPA	Utility Power Available Contact

NOTE: Specifications subject to change without notice.

CL064 Rev 0 05/02/15 4764Z/2K/3-05/BP/BH

THOMSON TECHNOLOGY • 9087A - 198th STREET, LANGLEY, BC CANADA V1M 3B1

TELEPHONE: (604) 888-0110 • FAX: (604) 888-3381 • E-MAIL: info@thomsontechnology.com • www.thomsontechnology.com