

Connection Diagram

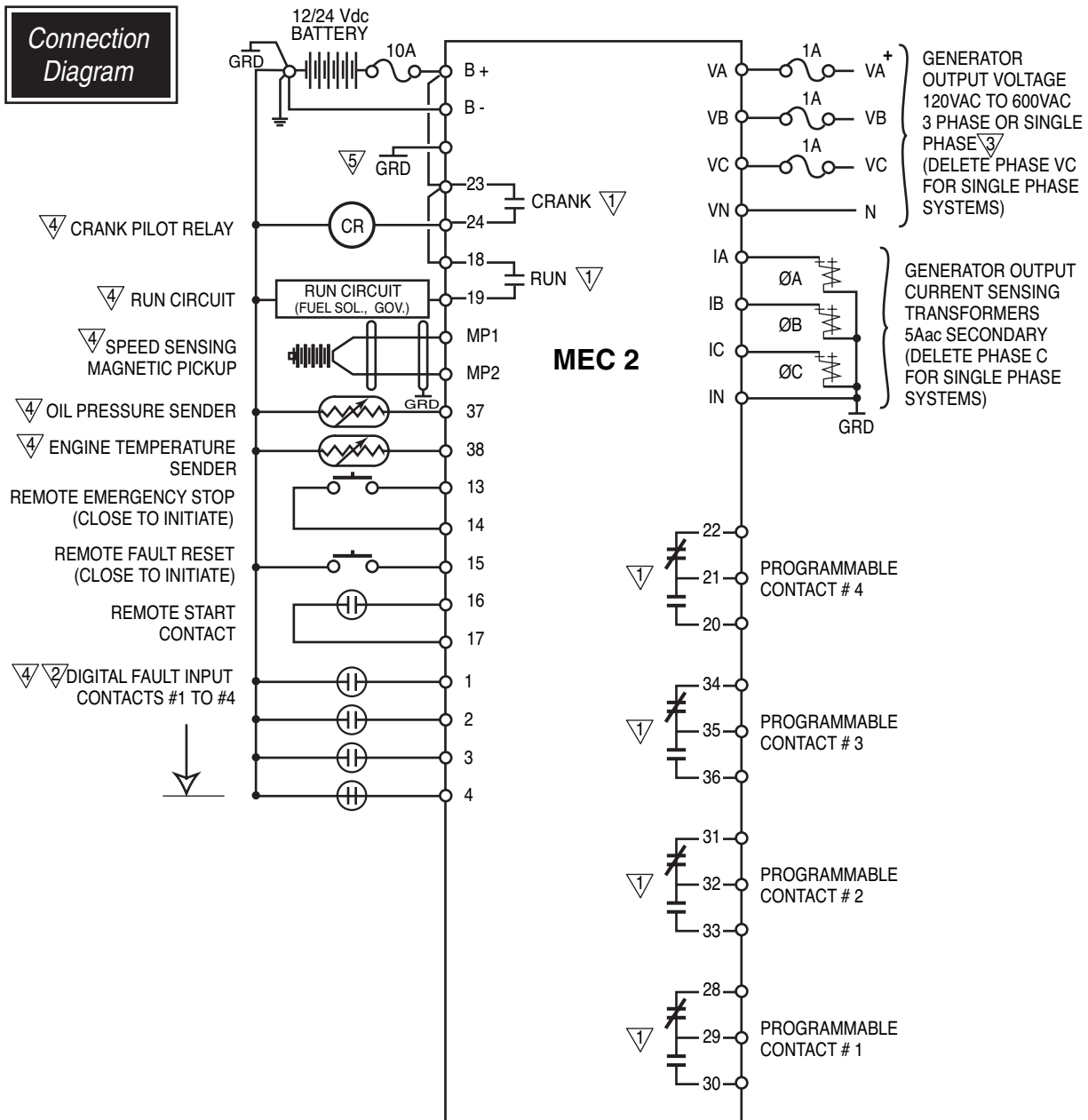

NOTES:

- 1 CONTACTS RATED MAXIMUM 10A/240VAC, 8A/24Vdc RESISTIVE
- 2 LOGIC IS SOFTWARE PROGRAMMABLE FOR OPEN OR CLOSE ON FAIL
- 3 GENERATOR SUPPLY MUST UTILIZE A SOLIDLY GROUNDED NEUTRAL SYSTEM—REFER TO INSTRUCTION MANUAL FOR ALTERNATE CONNECTIONS

- 4 ENGINE MOUNTED COMPONENTS
- 5 "GRD" CONNECTION TO BE MADE TO COMMON CHASSIS/ENCLOSURE GROUND BOND SYSTEM

NOTE: Specifications subject to change without notice.

CL052 REV 3 06/06/01

THOMSON TECHNOLOGY • 9087A - 198th STREET, LANGLEY, BC CANADA V1M 3B1

TELEPHONE: (604) 888-0110 • FAX: (604) 888-3381 • E-MAIL: info@thomsontechnology.com • www.thomsontechnology.com

MICROPROCESSOR ENGINE/GENERATOR CONTROLLER

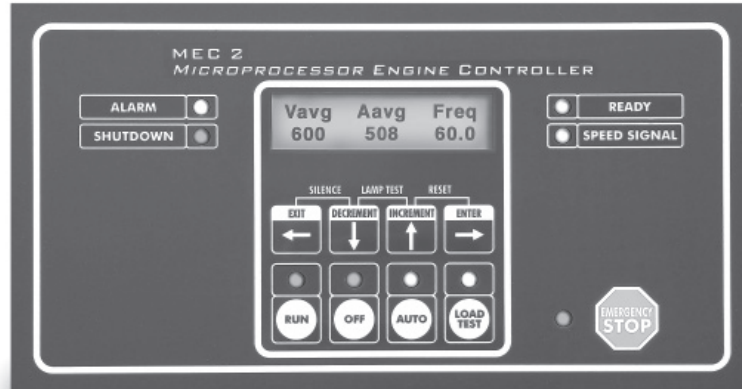

- Microprocessor-based circuitry provides ultimate reliability and versatility
- Standard features meet or exceed requirements as defined by NFPA 110 Level 1 and CSA C282
- Backlit LCD display screen with alpha-numeric readout for display and programming
- Digital 3-phase voltage, 3-phase current and frequency metering for generator output
- 19 alarm/shutdown fault circuits utilizing analog and digital inputs
- Alarm/shutdown indications are displayed in plain English language
- Auto mains failure (AMF) functionality
- Optional expansion output module for individual fault output contacts
- Password protected programming levels
- Self diagnostic features continuously verify processing, I/O and memory circuits
- Superior EMI/RFI noise immunity and surge performance features as per IEEE C62.41
- Certified to UL #508 and CSA 22.2 #14 Industrial Control Equipment Standards

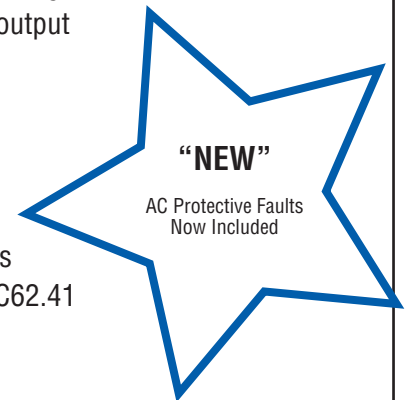

GENERAL DESCRIPTION

The Thomson Technology **MEC 2 Microprocessor-based Engine/Generator Controller** utilizes the latest advancements in microprocessor technology, printed circuit board assembly techniques and software development. This is the eighth generation of engine controllers from Thomson Technology, and reflects over 30 years of engine controller design experience, including a decade utilizing microprocessors. The result is an automatic engine/generator controller of superior design, providing a comprehensive array of operational, protection and display features. All functions of the **MEC 2** are fully configurable from the front panel keypad, and are password protected. The LCD display screen prompts are in plain English, providing a user-friendly operator interface with many display options available. The microprocessor design provides high accuracy for all voltage monitoring, current monitoring and timing functions as well as providing many standard features which are commonly available only as expensive add-on optional features on competitors'



STANDARD FEATURES

- **Alpha-Numeric Readout:** Display and Programming
- **Digital AC Metering:** 3 phase voltage \triangle (Phase to Phase and Phase to Neutral), 3 phase current, kVA, frequency
- **Digital Engine Gauge Display:** Oil Pressure, Engine Temperature, Hourmeter, Tachometer, DC Voltage
- **19 Standard Fault Circuits:**

SHUTDOWNS	ALARMS	
• Under voltage	• Weak Battery	• Switch Not in Auto \triangle
• Under frequency	• Low Battery Voltage	• Over frequency
• High Engine Temperature \triangle \triangle	• High Battery Voltage	• Over current
• Low Oil Pressure \triangle \triangle	• Battery Charger Input Fail \triangle	
• Over speed	• Low Engine Temperature	
• Loss of Speed Signal	• High Engine Temperature	
• Over crank	• Low Oil Pressure	
• Over voltage	• Low Fuel Level	

- **Timers:** Engine Start, Cooldown, Oil Bypass, Overcrank, Cycle crank
- **Control Switches:** Run/Off/Auto/Load Test, Horn Silence, Lamp Test, Fault Reset
- **Emergency Stop:** Faceplate mounted push-button and provision for remote contact input
- **LCD Display Menus:** AC metering, timer countdown functions, alarm/shutdown indication, engine parameters
- **LED Indicators:** Switch position (run, off, auto, load test), Common alarm, Common shutdown, Ready, Speed signal, Emergency stop, Mode of operation
- **AMF (Auto Mains Failure):** Control outputs and timers to control external transfer mechanism (refer to manual)
- **Diagnostic LED Indicators:** Watchdog (CPU running), run output energized, crank output energized, remote start signal initiated, common fail output energized
- **Audible Alarm Horn:** Programmable continuous or auto silence feature
- **Run & Crank Output Contacts:** (10A/240Vac, 8A/24Vdc, Form A)
- **4 Programmable Outputs:** (10A/240Vac, 8A/24Vdc, Form C):
User configured function (refer to programming functions available)
- **Provision for Remote Contact Inputs:** Emergency stop, Remote reset
- **Expansion Port:** Provision for addition of Expansion Port Module (Refer to Options)
- **Engine Senders:** Oil pressure (1/8" NPT), Temperature (1/4" NPT) supplied loose for engine mounting



Standard features meet or exceed requirements as defined by NFPA 110 Level 1 & CSA C282.



Requires customer-supplied sensing contact.



Generator supply must utilize a solidly grounded neutral system for standard panel connections.



High Engine Temperature and Low Oil Pressure shutdowns are factory programmed to utilize both digital contact and analog sender inputs.

NOTE: Customer to supply and install engine-mounted crank pilot relay, magnetic pickup and current transformers.

OPTIONAL FEATURES

- **VFD** Vacuum fluorescent display for extended low temperature operation (-40°C)
- **MEC O & M** Additional O & M Manual (One manual is included with each unit shipped)
- **EXP** 16 point relay expansion module for individual fault output contacts on MEC 2. Relay contacts are configurable (normally open or closed) and are rated 0.5A 120VAC, 1.0A 30Vdc resistive (maximum)
- **EAP 110** Remote annunciator with data communication link. 20 light annunciator for NFPA 110 (Level 1) & CSA282-00 faults*

* (Refer to separate literature for additional information)

